

Startup Guide

Keysight M9202A PXIe Wideband IF Digitizer

12-bit, up to 2 GS/s
and 1 GHz bandwidth



Notice: This document contains references to Agilent. Please note that Agilent's Test and Measurement business has become Keysight Technologies. For more information, go to www.keysight.com.

Notices

Copyright Notice

© Keysight Technologies 2012 - 2015

No part of this manual may be reproduced in any form or by any means (including electronic storage and retrieval or translation into a foreign language) without prior agreement and written consent from Keysight Technologies, Inc. as governed by United States and international copyright laws.

Manual Part Number

M9202-90001

Published By

Keysight Technologies
Chemin des Aulx, 12
1228 Plan-Les-Ouates
Switzerland

Edition

Edition 2, November, 2015
Printed In USA

Regulatory Compliance

This product has been designed and tested in accordance with accepted industry standards, and has been supplied in a safe condition. To review the Declaration of Conformity, go to <http://www.keysight.com/go/conformity>.

Warranty

THE MATERIAL CONTAINED IN THIS DOCUMENT IS PROVIDED "AS IS," AND IS SUBJECT TO BEING CHANGED, WITHOUT NOTICE, IN FUTURE EDITIONS. FURTHER, TO THE MAXIMUM EXTENT PERMITTED BY APPLICABLE LAW, KEYSIGHT DISCLAIMS ALL WARRANTIES, EITHER EXPRESS OR IMPLIED, WITH REGARD TO THIS MANUAL AND ANY INFORMATION CONTAINED HEREIN, INCLUDING BUT NOT LIMITED TO THE IMPLIED WARRANTIES OF MERCHANTABILITY AND FITNESS FOR A PARTICULAR PURPOSE. KEYSIGHT SHALL NOT BE LIABLE FOR ERRORS OR FOR INCIDENTAL OR CONSEQUENTIAL DAMAGES IN CONNECTION WITH THE

FURNISHING, USE, OR PERFORMANCE OF THIS DOCUMENT OR OF ANY INFORMATION CONTAINED HEREIN. SHOULD KEYSIGHT AND THE USER HAVE A SEPARATE WRITTEN AGREEMENT WITH WARRANTY TERMS COVERING THE MATERIAL IN THIS DOCUMENT THAT CONFLICT WITH THESE TERMS, THE WARRANTY TERMS IN THE SEPARATE AGREEMENT SHALL CONTROL. KEYSIGHT TECHNOLOGIES DOES NOT WARRANT THIRD-PARTY SYSTEM-LEVEL (COMBINATION OF CHASSIS, CONTROLLERS, MODULES, ETC.) PERFORMANCE, SAFETY, OR REGULATORY COMPLIANCE, UNLESS SPECIFICALLY STATED.

Technology Licenses

The hardware and/or software described in this document are furnished under a license and may be used or copied only in accordance with the terms of such license.

U.S. Government Rights

The Software is "commercial computer software," as defined by Federal Acquisition Regulation ("FAR") 2.101. Pursuant to FAR 12.212 and 27.405-3 and Department of Defense FAR Supplement ("DFARS") 227.7202, the U.S. government acquires commercial computer software under the same terms by which the software is customarily provided to the public. Accordingly, Keysight provides the Software to U.S. government customers under its standard commercial license, which is embodied in its End User License Agreement (EULA), a copy of which can be found at <http://www.keysight.com/find/sweula>. The license set forth in the EULA represents the exclusive authority by which the U.S. government may use, modify, distribute, or disclose the Software. The EULA and the license set forth therein, does not require or permit, among other things, that Keysight: (1) Furnish technical information related to commercial computer software or commercial computer software documentation that is not customarily provided to the public; or (2) Relinquish

to, or otherwise provide, the government rights in excess of these rights customarily provided to the public to use, modify, reproduce, release, perform, display, or disclose commercial computer software or commercial computer software documentation. No additional government requirements beyond those set forth in the EULA shall apply, except to the extent that those terms, rights, or licenses are explicitly required from all providers of commercial computer software pursuant to the FAR and the DFARS and are set forth specifically in writing elsewhere in the EULA. Keysight shall be under no obligation to update, revise or otherwise modify the Software. With respect to any technical data as defined by FAR 2.101, pursuant to FAR 12.211 and 27.404.2 and DFARS 227.7102, the U.S. government acquires no greater than Limited Rights as defined in FAR 27.401 or DFAR 227.7103-5 (c), as applicable in any technical data.

Safety Notices

CAUTION

A CAUTION notice denotes a hazard. It calls attention to an operating procedure, practice, or the like that, if not correctly performed or adhered to, could result in damage to the product or loss of important data. Do not proceed beyond a CAUTION notice until the indicated conditions are fully understood and met.

WARNING

A WARNING notice denotes a hazard. It calls attention to an operating procedure, practice, or the like that, if not correctly performed or adhered to, could result in personal injury or death. Do not proceed beyond a WARNING notice until the indicated conditions are fully understood and met.

The following safety precautions should be observed before using this product and any associated instrumentation.

This product is intended for use by qualified personnel who recognize shock hazards and are familiar with the

safety precautions required to avoid possible injury. Read and follow all installation, operation, and maintenance information carefully before using the product.

WARNING

If this product is not used as specified, the protection provided by the equipment could be impaired. This product must be used in a normal condition (in which all means for protection are intact) only.

The types of product users are:

- Responsible body is the individual or group responsible for the use and maintenance of equipment, for ensuring that the equipment is operated within its specifications and operating limits, and for ensuring operators are adequately trained.
- Operators use the product for its intended function. They must be trained in electrical safety procedures and proper use of the instrument. They must be protected from electric shock and contact with hazardous live circuits.
- Maintenance personnel perform routine procedures on the product to keep it operating properly (for example, setting the line voltage or replacing consumable materials). Maintenance procedures are described in the user documentation. The procedures explicitly state if the operator may perform them. Otherwise, they should be performed only by service personnel.
- Service personnel are trained to work on live circuits, perform safe installations, and repair products. Only properly trained service personnel may perform installation and service procedures.

WARNING

Operator is responsible to maintain safe operating conditions. To ensure safe operating conditions, modules should not be operated beyond the full temperature range specified in the Environmental and physical specification. Exceeding safe operating conditions can result in shorter lifespans, improper module performance and user safety issues. When the modules are in use and operation within the specified full

temperature range is not maintained, module surface temperatures may exceed safe handling conditions which can cause discomfort or burns if touched. In the event of a module exceeding the full temperature range, always allow the module to cool before touching or removing modules from chassis.

Keysight products are designed for use with electrical signals that are rated Measurement Category I and Measurement Category II, as described in the International Electrotechnical Commission (IEC) Standard IEC 60664. Most measurement, control, and data I/O signals are Measurement Category I and must not be directly connected to mains voltage or to voltage sources with high transient over-voltages. Measurement Category II connections require protection for high transient over-voltages often associated with local AC mains connections. Assume all measurement, control, and data I/O connections are for connection to Category I sources unless otherwise marked or described in the user documentation.

Exercise extreme caution when a shock hazard is present. Lethal voltage may be present on cable connector jacks or test fixtures. The American National Standards Institute (ANSI) states that a shock hazard exists when voltage levels greater than 30V RMS, 42.4V peak, or 60VDC are present. A good safety practice is to expect that hazardous voltage is present in any unknown circuit before measuring.

Operators of this product must be protected from electric shock at all times. The responsible body must ensure that operators are prevented access and/or insulated from every connection point. In some cases, connections must be exposed to potential human contact. Product operators in these circumstances must be trained to protect themselves from the risk of electric shock. If the circuit is capable of operating at or above 1000V, no conductive part of the circuit may be exposed.

Do not connect switching cards directly to unlimited power circuits. They are

intended to be used with impedance-limited sources. NEVER connect switching cards directly to AC mains. When connecting sources to switching cards, install protective devices to limit fault current and voltage to the card.

Before operating an instrument, ensure that the line cord is connected to a properly-grounded power receptacle. Inspect the connecting cables, test leads, and jumpers for possible wear, cracks, or breaks before each use.

When installing equipment where access to the main power cord is restricted, such as rack mounting, a separate main input power disconnect device must be provided in close proximity to the equipment and within easy reach of the operator.

For maximum safety, do not touch the product, test cables, or any other instruments while power is applied to the circuit under test. ALWAYS remove power from the entire test system and discharge any capacitors before: connecting or disconnecting cables or jumpers, installing or removing switching cards, or making internal changes, such as installing or removing jumpers.

Do not touch any object that could provide a current path to the common side of the circuit under test or power line (earth) ground. Always make measurements with dry hands while standing on a dry, insulated surface capable of withstanding the voltage being measured.

The instrument and accessories must be used in accordance with its specifications and operating instructions, or the safety of the equipment may be impaired.

Do not exceed the maximum signal levels of the instruments and accessories, as defined in the specifications and operating information, and as shown on the instrument or test fixture panels, or switching card.

When fuses are used in a product, replace with the same type and rating for continued protection against fire hazard.

Chassis connections must only be used as shield connections for measuring circuits, NOT as safety earth ground connections.

If you are using a test fixture, keep the lid closed while power is applied to the device under test. Safe operation requires the use of a lid interlock.

Instrumentation and accessories shall not be connected to humans.

Before performing any maintenance, disconnect the line cord and all test cables.

To maintain protection from electric shock and fire, replacement components in mains circuits – including the power transformer, test leads, and input jacks – must be purchased from Keysight. Standard fuses with applicable national safety approvals may be used if the rating and type are the same. Other components that are not safety-related may be purchased from other suppliers as long as they are equivalent to the original component (note that selected parts should be purchased only through Keysight to maintain accuracy and functionality of the product). If you are unsure about the applicability of a replacement component, call an Keysight office for information.

WARNING

No operator serviceable parts inside. Refer servicing to qualified personnel. To prevent electrical shock do not remove covers. For continued protection against fire hazard, replace fuse with same type and rating.

PRODUCT MARKINGS:



The CE mark is a registered trademark of the European Community.



Australian Communication and Media Authority mark to indicate regulatory compliance as a registered supplier.



This symbol indicates product compliance with the Canadian Interference-Causing Equipment Standard (ICES-001). It also identifies the product is an Industrial Scientific and Medical Group 1 Class A product (CISPR 11, Clause 4).



South Korean Class A EMC Declaration. This equipment is Class A suitable for professional use and is for use in electromagnetic environments outside of the home. A 급 기기 (업무용 방송통신기자재) 이 기기는 업무용 (A 급) 전자파적합기기로서 판매자 또는 사용자는 이 점을 주의하시기 바라며, 가정외의 지역에서 사용하는 것을 목적으로 합니다.



This product complies with the WEEE Directive marketing requirement. The affixed product label (above) indicates that you must not discard this electrical/electronic product in domestic household waste. **Product Category:** With reference to the equipment types in the WEEE directive Annex 1, this product is classified as “Monitoring and Control instrumentation” product. Do not dispose in domestic household waste. To return unwanted products, contact your local Keysight office, or for more information see <http://about.keysight.com/en/companyinfo/environment/takeback.shtml>.



This symbol indicates the instrument is sensitive to electrostatic discharge (ESD). ESD can damage the highly sensitive components in your instrument. ESD damage is most likely to occur as the module is being installed or when cables are connected or disconnected. Protect the circuits

from ESD damage by wearing a grounding strap that provides a high resistance path to ground. Alternatively, ground yourself to discharge any built-up static charge by touching the outer shell of any grounded instrument chassis before touching the port connectors.



This symbol on an instrument means caution, risk of danger. You should refer to the operating instructions located in the user documentation in all cases where the symbol is marked on the instrument.



This symbol indicates the time period during which no hazardous or toxic substance elements are expected to leak or deteriorate during normal use. Forty years is the expected useful life of the product.



This symbol denotes a hot surface. The side cover of the module will be hot after use and should be allowed to cool for several minutes.

CLEANING PRECAUTIONS:

WARNING

To prevent electrical shock, disconnect the Keysight Technologies instrument from mains before cleaning. Use a dry cloth or one slightly dampened with water to clean the external case parts. Do not attempt to clean internally. To clean the connectors, use alcohol in a well-ventilated area. Allow all residual alcohol moisture to evaporate, and the fumes to dissipate prior to energizing the instrument.

Contents

Documentation Map	6
M9202A PXIe Wideband IF Digitizer Introduction	7
Step 1: Unpack and Inspect the Module	9
Electrostatic Discharge (ESD) Precautions	9
Inspect for Damage	9
Return a Module for Service	10
Step 2: Verify M9202A Shipment Contents	11
Step 3: Install the Software	12
System Requirements	12
Hardware Requirements	13
Install the Software	13
Keysight IO Libraries Suite (IOLS)	13
Instrument software	13
Power up the Controller	14
Remote Controller	14
Embedded Controller	14
Step 4: Install the Module	15
M9202A Front Panel Features	17
Step 5: Verify Operation of the M9202A Module	18
Keysight M9202A Instrument Properties	18
Keysight M9202A Installed Software	18
Conducting a Self-Test	19
Perform a Verification of the M9202A (optional)	19

Documentation Map

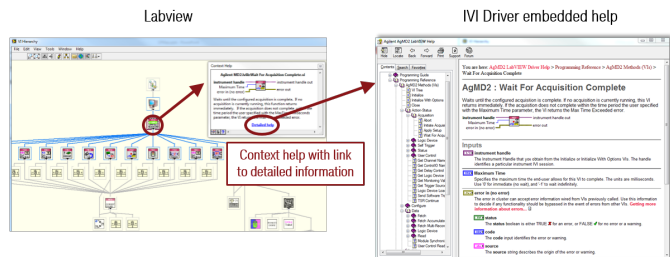
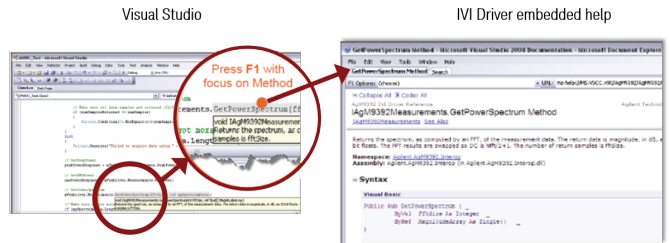
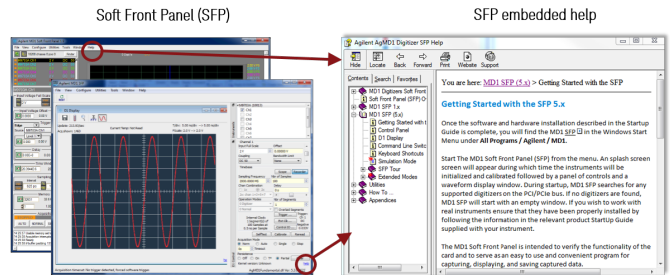
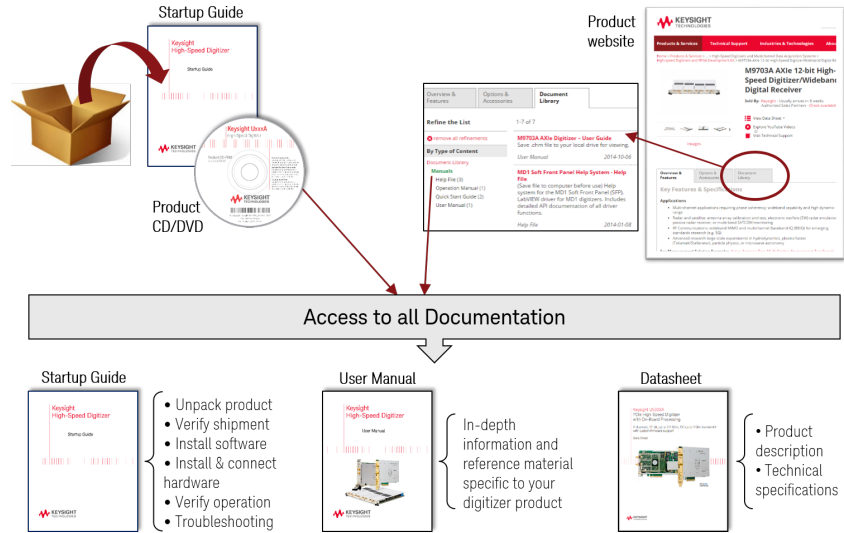

M9202A PXIe Wideband IF Digitizer Introduction

The scope of this Startup Guide is to detail the processes of receiving and installing the Keysight M9202A PXIe Wideband IF Digitizer, installing the required software, and verifying basic module operation.

If you have any questions after reviewing this information, please contact your local Keysight representative or contact us through our website at

www.keysight.com/find/contactus.

Related Documentation

This Startup Guide and the documentation listed below are contained on the CD supplied with your product. and at

www.keysight.com/find/M9202A.

Select **Document Library** > **Manuals**

- M9202A User Manual
- Help system for the Soft Front Panel
- Help systems for the Keysight device drivers (IVI-C and IVI-COM, and LabVIEW G)

Or Select **Document Library** > **Specifications**

- Product specifications for the Datasheet.

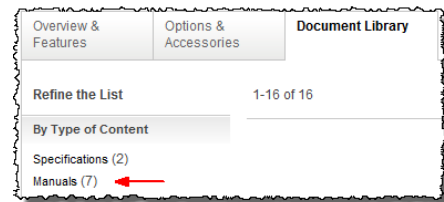

Follow the Startup Sequence

This Start-Up Guide is intended to lead the user through the four steps of product installation as summarized in the diagram below. An optional fifth step shows how to perform an operational verification of the M9202A PXIe Wideband IF Digitizer.

Step 1: Unpack and Inspect



Step 2: Verify Shipment



Step 3: Install Drivers and Software



Step 4: Install Modules



WARNING

Closely follow the startup process flow in this document. Deviating from the sequence can cause unpredictable system behavior, damage your system, and may cause personal injury.

Step 1: Unpack and Inspect the Module

CAUTION The module is shipped in materials which prevent damage from static. The module should only be removed from the packaging in an anti-static area ensuring that correct anti-static precautions are taken. Store all modules in anti-static envelopes when not in use.

Electrostatic Discharge (ESD) Precautions

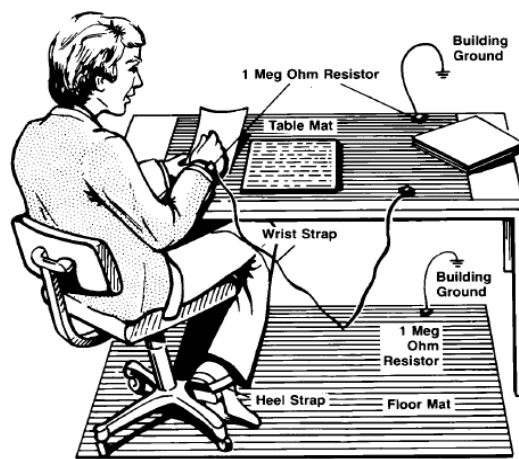

Electrostatic discharge (ESD) can damage or destroy electronic components. Use a static-safe work station to perform all work on electronic assemblies. The figure (left) shows a static-safe work station using two types of ESD protection: conductive table-mat and wrist-strap combination, and conductive floor-mat and heel-strap combination. Both types, when used together, provide a significant level of ESD protection. Of the two, only the table-mat and wrist-strap combination

provides adequate ESD protection when used alone. To ensure user safety, the static-safe accessories must provide at least 1 M Ω of isolation from ground.

WARNING DO NOT use these techniques for a static-safe work station when working on circuitry with a voltage potential greater than 500 volts.

Inspect for Damage

After unpacking a module, inspect it for any shipping damage. Report any damage to the shipping agent immediately, as such damage is not covered by the warranty (see warranty information at beginning of this document).

CAUTION To avoid damage when handling a module, do not touch any exposed components or connector pins.

NOTE See <http://www.keysight.com/find/tips> for information on preventing damage to your Keysight equipment.

Return a Module for Service

Should it become necessary to return a module for repair or service, follow the steps below:

1. Review the warranty information shipped with your product.
2. Contact Keysight to obtain a Return Material Authorization (RMA) and return address. For assistance finding Keysight contact information, go to www.keysight.com/find/assist (worldwide contact information for repair and service) or refer to the “Support” information on the product web page at www.keysight.com/find/M9202A.
3. Write the following information on a tag and attach it to the malfunctioning equipment:
 - Name and address of owner. A P.O. box is not acceptable as a return address.
 - Product model number (for example, M9202A).
 - Product serial number. The serial number label is located on the top cover of the module. The serial number can also be read from the Soft Front Panel interface, but only after the hardware is installed.
 - Description of failure or service required.
4. Pack the module in its original ESD bag and packing carton. If the original carton is not available, use bubble wrap or packing peanuts and place the instrument in a sealed container and mark the container “FRAGILE”.
5. On the shipping label, write ATTENTION REPAIR DEPARTMENT and the RMA number.

NOTE

If any correspondence is required, refer to the product by serial number and model number.

Step 2: Verify M9202A Shipment Contents

The following items are also included with your M9202A PXIe Wideband IF Digitizer order:

Part Number	Quantity	Description
M9202A	1	PXIe Wideband IF Digitizer.
M9210-90007	1	Keysight MD1 High-Speed Digitizer Software and Product Information DVD
E2094-60003	1	Keysight IO Libraries Suite CD.
M9202-90001	1	Startup Guide in hard copy.
5962-0476	1	Certificate of Calibration.
5964-8178	1	Form-determining recalibration due date.
9320-6741	1	ROHS (China addendum).
8121-2041	2	Cable, coaxial 50 Ω SMB-MMCX (190 mm)
8121-2042	1	Cable, coaxial 50 Ω SMB-MMCX (80 mm)
8120-5531	1	Cable, coaxial 50 Ω SMA-SMB (190 mm)

NOTE

All the files contained on the CDs are available for download at www.keysight.com/find/M9202A.

Step 3: Install the Software

System Requirements

Item	Requirements	
Operating system	Windows 7® (32 or 64-bit), All versions.	Linux kernel 2.6 or higher (32 or 64-bit), Debian 6.0, CentOS 5
Processor speed	1 GHz 32-bit (x86), 1 GHz 64-bit (x64), no support for Itanium64	As per the minimum requirements of the chosen distribution.
Available memory	1 GB minimum	As per the minimum requirements of the chosen distribution.
Available disk space ¹	1.5 GB available hard disk space, includes: <ul style="list-style-type: none"> – 1 GB available for Microsoft .NET Framework 3.5 SP1 ² – 100 MB for Keysight IO Libraries Suite 	100 MB
Video	Support for DirectX 9 graphics with 128 MB graphics memory recommended (Super VGA graphics is supported)	Does not require graphics (headless system). X Windows with 1280x1024 recommended for SFP
Browser	Microsoft Internet Explorer 7.0 or higher	Distribution supplied browser.

¹ Because of the installation procedure, less disk space may be required for operation than is required for installation. The amount of space listed above is required for installation.

² .NET Framework Runtime Components are often installed by default with Windows Vista and later versions. Therefore, you may not need this amount of available disk space.

Hardware Requirements

Item	Requirements
Chassis	PXIe chassis
PXI System / Host Controller	A remote PC Host or PXI Express embedded controller is required
· Embedded Controller	An embedded PC host controller must meet the following requirements: <ul style="list-style-type: none"> · PXIe System Controller (in PXIe chassis) · Utilize a 2x8, 4x4, 1x8, or 1x4 PXIe System slot link configuration · Run one of the above operating systems
· Remote Controller	Keysight M9021A PXIe System Interface x8 with one of the following PC interface options: <ul style="list-style-type: none"> · Keysight M9045B PCIe ExpressCard Adaptor x1, with cable (for laptops) · Keysight M9048A PCIe Desktop Adaptor Or an equivalent remote controller connected to a PC running one of the above operating systems.

Install the Software

Keysight IO Libraries Suite (IOLS)

Keysight IO Libraries Suite (IOLS), which includes the Keysight Connection Expert. This software is included with your shipment (CD part number E2904-60003), and is also available at www.keysight.com/find/IOsuite. This software must be installed first.

1. From the Keysight IOLS CD (E2904-60003) browser launch the installer.
2. Follow the installer prompts to install the IO libraries.

NOTE

For Keysight IO Libraries Suite, it is recommended to use the version indicated on MD1 Driver DVD or later.

Instrument software

Instrument software, which includes device drivers (IVI-C, IVI-COM) and documentation for your module. This software is included with your shipment (DVD part number M9210-90007).

1. From the Keysight MD1 High-Speed Digitizer Software and Product Information DVD launch the installer.
2. Follow the installer prompts. Choose a "Complete" installation to install all software and documentation, or a "Custom" installation to select from a listing of components and other features.
3. After installation is complete, please shut-down the PC.

Power up the Controller

Remote Controller

If you are using a remote controller, install the cable interface and then power up the host PC. If you are using an Keysight M9045B or M9048A Interface, please refer to the included documentation for further details.

CAUTION

If you are using a remote controller, Shut Down the PC **BEFORE** you power down the chassis. When you restore power, power up the chassis, and wait for the chassis & module status indicators to be ready **BEFORE** you power up the PC.

Embedded Controller

If you are using an embedded controller, complete the following steps:

1. Install the embedded controller module into the compatible chassis. The Keysight M9018A PXIe chassis is recommended. Please refer to the chassis documentation for further details.
2. Connect peripherals (mouse, keyboard, monitor), then power up the chassis.

Step 4: Install the Module

CAUTION PXI hardware does not support "hot-swap" operation. Before installing the module into the chassis, power off the chassis to prevent damage to the module.

4 The module can be installed in any PXIe slot marked with a peripheral slot compatibility image (a circle containing the slot number).

7^H The module can also be installed in any hybrid PXIe slot marked with a peripheral slot compatibility image (the letter "H" and a solid circle containing the slot number).

1. Make sure the chassis is connected to the main supply, but power switch is in the Off (Standby) position.
2. If the chassis has multiple fan speed settings, ensure that the fans are set to automatic. Do not set the fan speed to low or turn it off.
3. Position the chassis so that there is ample space between the chassis fan intake and exhaust vents.
4. If using a remote controller, install the System Interface Card in the slot identified by the triangle symbol: 
5. Install the module into the appropriate slot of the chassis by placing the module card edges into the front module guides (top and bottom), Ensure that the ejector handle is pushed down and slide it to the rear.
6. When resistance is felt, latch the module by pulling up on the ejector handle.

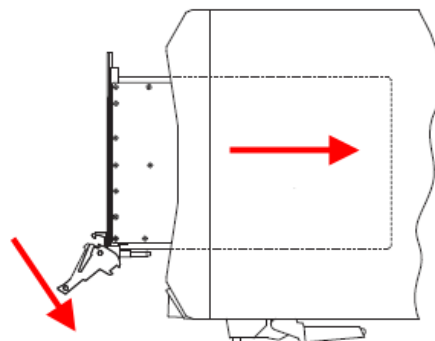

Installing a module into a PXI chassis

7. Tighten the screws on the module front panel. Performance may suffer if the screws are not tightened.

Step 4: Install the Module

8. Verify that the chassis fans are operable and free of dust and other contaminants that may restrict airflow.
9. Install all chassis covers and filler panels after installing the module. Missing filler panels may disrupt necessary air circulation in the chassis.
10. Plug in and power up the PXI chassis. (If you are using a remote controller, reboot the host PC.)
11. Check the status LED on the module front panel, It should be orange or red when the power is applied, If not there is a problem with either the module or the chassis.
12. Follow the New Hardware Wizard's instructions to install the driver.
13. Reboot the system.



M9202A Front Panel Features

Front Panel Connectors



Connector	Description
TRG 1	This MMCX female connector is a 50 Ω terminated input for an external trigger signal. The trigger signal range is ± 5 V.
TRG 2	This MMCX female connector is a 50 Ω terminated input for an external trigger signal. The trigger signal range is ± 5 V.
TRG 3	This MMCX female connector is a 50 Ω terminated input for an external trigger signal. The trigger signal range is ± 5 V.
INPUT 1	This SMA female connector is the analog signal input. This input is AC-coupled and 50 Ω terminated. The input full scale range is 1 V (+4 dBm). Frequency range: 30 MHz to 1 GHz. Maximum signal is 30 dBm.
CLK 1 IN	This SMA female connector is the external clock signal input. This input is AC-coupled and 50 Ω terminated. The recommended signal level is 1 V pk-pk (+4 dBm). The clock signal frequency should be half of the desired sampling frequency.
TRG OUT	This MMCX female connector features a trigger signal output.
REF IN	This MMCX female connector is the clock external reference input (100 MHz). This input is AC-coupled and 50 Ω terminated. The recommended signal level is 1 V pkpk (+4 dBm).

Front Panel LED

LED State	Description
	Power is not present or the module has a fault.
	Indicates that a trigger has occurred, and the acquisition is complete.
	Identifies the module associated with the current channel in the Soft Front Panel when the 'Identify' function is used.

Step 5: Verify Operation of the M9202A Module

The intention of this step is to verify correct operation of the newly installed module. Run Keysight Connection Expert by right-clicking the task bar icon , and select **Keysight Connection Expert**.

It will display the modules that are installed. Review the configuration data and then launch the SFP. This will provide control of the module for self test and other operational verification procedures.

Keysight M9202A Instrument Properties

The instrument properties may be viewed by clicking on the desired instrument and then on the **Instrument Properties** tab in the right panel.

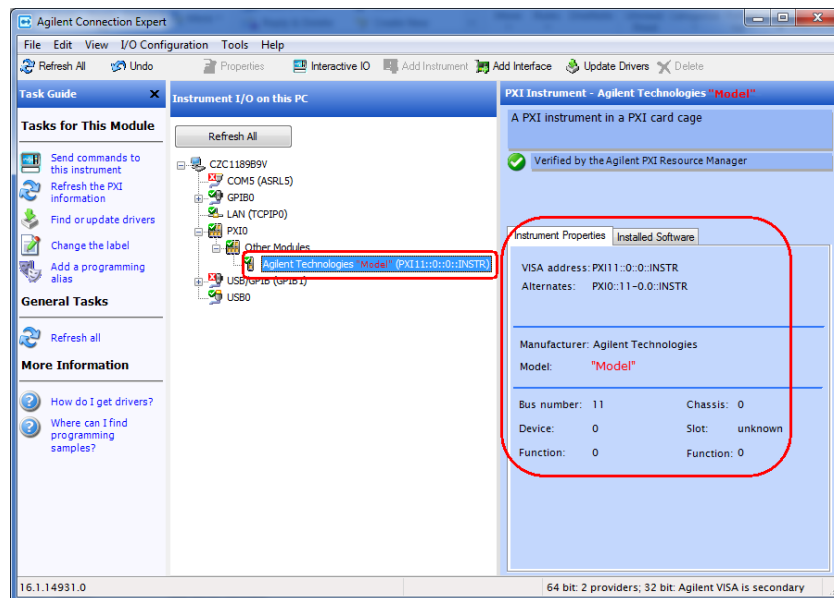

Agilent or Keysight Connexion Expert (Interface differs depending on IO Library Suite version)

NOTE

If the module does not appear in the Keysight Connection Expert, first try the 'Refresh All' button. If that does not work, restart your PC or embedded controller and start Keysight Connection Expert again.

Keysight M9202A Installed Software

The SFP 5 application may be launched from the list installed software, by clicking the **Start Soft Front Panel** button.

The SFP 1 application may be launched from **Window Start Menu > Agilent > MD1 Digitizer > SFP 1.11**.

Conducting a Self-Test

The purpose of this self-test is to verify that the unit functions correctly, in that it can self-calibrate and communicate with the processor controlling it.

Start the SFP 1 from **Window Start Menu > Agilent > MD1 Digitizer > SFP 1.11**.

When the SFP 1 is launched it will initiate a self-calibration which might take a little over 1 minute.

Verify that no error is shown in the lower left hand log area. The image below shows the desired result.

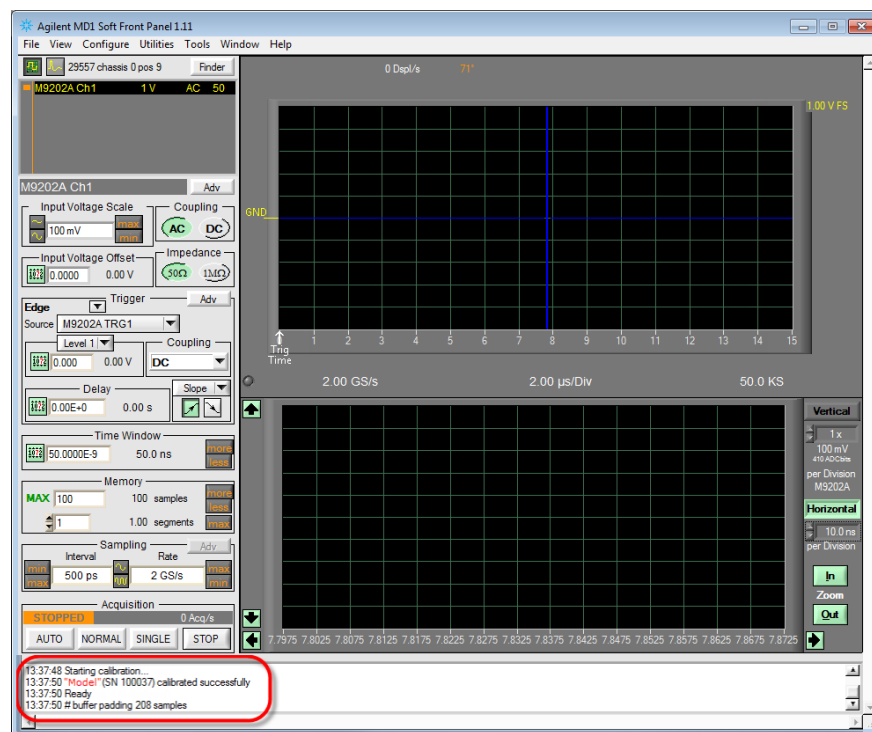

Soft Front Panel (SFP 1) showing the result of the Self-Test

Perform a Verification of the M9202A (optional)

Requirements for Verification

The M9202A is verified by using it to trigger on and visualize a signal from a Function Generator. The trigger must be stable and the signal frequency and amplitude must correspond to that set on the generator.

Required Hardware

To verify that the module works requires an external signal source which will be sent to both the input and the trigger. Almost any sine wave or function generator capable of generating a signal with a Peak-Peak Amplitude in the range 0.1-2 V at a frequency in the range 100-500 MHz can be used. The rest of this description will assume that an Keysight N5181A MXG RF Analog Signal Generator is available for this purpose.

Hardware	Description
Keysight N5181A	MXG RF Analog Signal Generator
1x BNC - BNC cable	50 Ω Coaxial BNC(m) - BNC(m) cable (min 20 cm)
1x Keysight 11667L Splitter	DC to 2 GHz Power Splitter with BNC connector
1x BNC - SMA cable	50 Ω Coaxial BNC(m) to SMA(m) cable (100 cm)
1x Keysight 1250-1476 Adaptor	Type N(m) to BNC(f) adaptor
1x BNC - MMCX cable	50 Ω Coaxial (100 cm)

Operational Verification Procedure

CAUTION Do not exceed the maximum power level to the INPUT connector (0.5 W).

1. Launch the soft front panel (SFP 1) from **Window Start Menu > Agilent > MD1 Digitizer > SFP 1.11**. The calibration must successfully end as noted above.
2. Configure the Signal Generator to produce a Sine signal with a Frequency of 100 MHz, an Amplitude of 560 mV pp (+8.0 dBm), and an Offset of 0 V.
3. Connect the RF GENERATOR output to the Splitter with the Adaptor and the BNC-BNC cable. Using the BNC-SMA cable, connect one Splitter output to INPUT 1. Use the BNC-MMCX cable to connect the other Splitter output to the TRG1 input. Turn on the RF GENERATOR output.
4. Configure the SFP for the Oscilloscope Mode. 
5. Select the 'Connect data points' option from the 'View' menu.
6. Configure the Input for:

- Trigger Level 1 – 0.0 V	- Input Voltage Offset – 0.0
- Trigger Delay – 0.0	- Trigger Source – M9202A EXT1
- TimeWindow – 50 ns/Div	- Trigger Coupling – DC
- Segments – 1	- Trigger Slope – Positive
- Memory – 100	
7. Select the NORMAL Acquisition mode and the Waveform Display should be as shown below.

8. Verify that:
 - the waveform shown is stable from one acquisition to the next,
 - the period of the signal is 2 divisions
 - the pk-pk amplitude is 8 ± 0.6 divisions

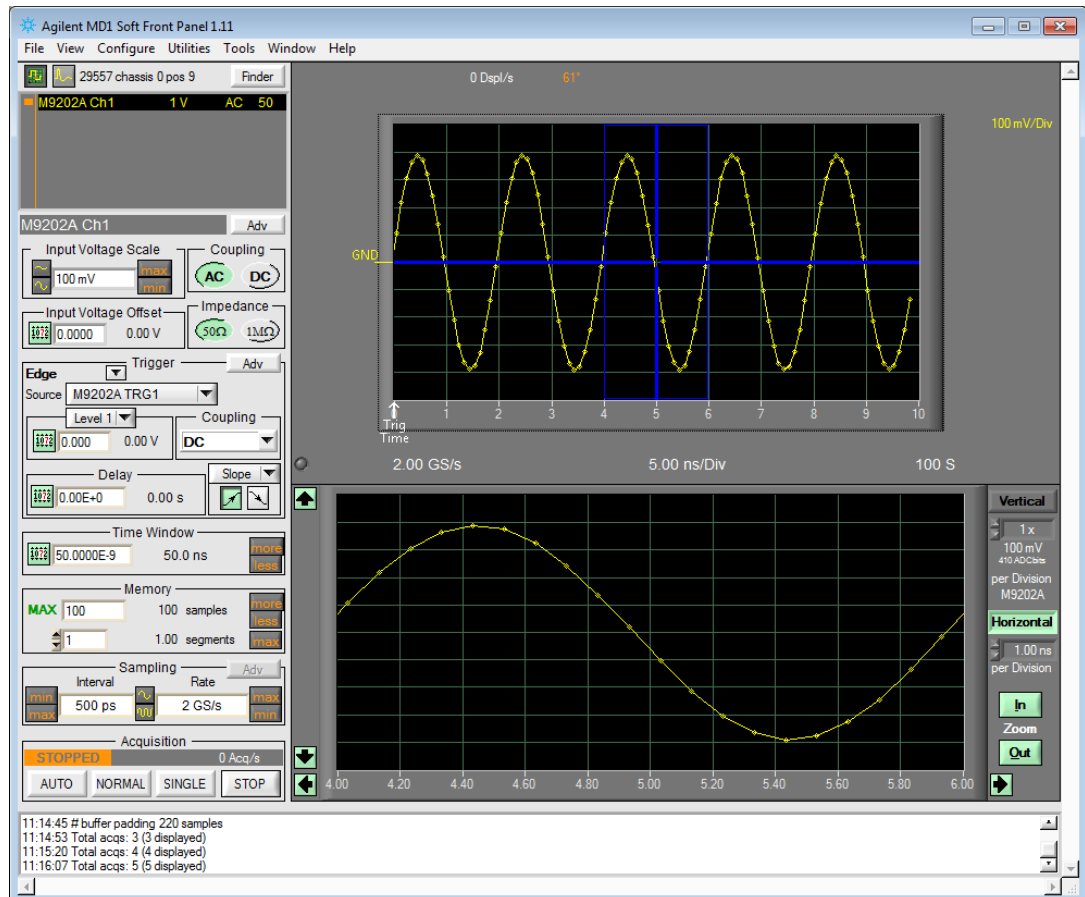

SFP showing measured waveform

If a Problem is Found

1. Verify that you have set all configuration settings as shown above.
2. Verify that the RF Generator is ON and producing the desired signals at the end of the BNC cables. This can be done with an oscilloscope.
3. If the problem occurs during Operational Verification disconnect the input signal and note the status of the LED on the front panel; it should be GREEN. Reconnect the signal and select the AUTO acquisition mode; note the behavior for subsequent reference.
4. Verify that the problem is reproducible.
5. Refer to [Return a Module for Service \(page 10\)](#), concerning the details on sending the module to Keysight for service.



This information is subject to change
without notice.
© Keysight Technologies 2012 - 2015
Edition 2, November, 2015
Printed In USA

M9202-90001
www.keysight.com